

# **CavBase-Visualization and Database for Cavern Construction, Solution Mining Process, Brine Production and Product Storage**

Ralph M. Gaertner, Christian Hellberg and Dr. Heinz F. Wilke  
DEEP. Underground Engineering GmbH  
Eyhauser Allee 2 a, 26160 Bad Zwischenahn, Germany  
Website: [www.deep.de](http://www.deep.de), E-mail: [info@deep.de](mailto:info@deep.de)

## **Summary**

During the planning and construction of cavern bore holes, during the mining process of caverns as well as during storage operations, a tremendous amount of data has to be collected. Normally these data are stored in file cabinets, on spreadsheets, as scattered notes or even in the heads of the engineers and operators.

CavBase is a database system specifically designed for collecting and storing cavern-related information in one designated environment, either for individual caverns and for complete cavern fields. Besides the cavern each piece of information has always a date attached. The date is the key element of the whole database system.

The data management of the CavBase system is complemented by a variety of output features, e.g. daily, weekly, monthly reports, lists and tables of technical details, historical changes of cavern configurations, production figures, statistical evaluations and graphical analysis. Self-describing menus and buttons lead the user in an accustomed manner through the whole system and help him to enter data, to analyze and visualize his operations and to prepare and customize reports and figures.

The software package CavBase, usable for

- brine/salt production,
- cavern construction in general and
- operation of liquid storage,

has been established:

- to support the operator for the daily production routine,
- to assist the engineer in his planning and decision-making process,
- to provide for the different external reporting in a corporate design,
- to enable the management to get fast and reliable access to the cavern field status and as a consequence
- to save time and costs.

## 1 Introduction

For more than 50 years now, ever since the extraction of salt and brine from solution caverns was first started, engineers and geologists have collected all kinds of information necessary to keep track of the drilling and mining process. The initial reasons for collecting and storing this data were:

- production balance,
- improvement of technology by learning through experience,
- reporting requirements of the authorities,
- maintenance of cavern development and
- historical data base.

As geology and other circumstances influence the mining process and determine its development, it has always been difficult to standardize the construction of a cavern. Therefore, all available information has been used all the time to improve the “trial and error method” of cavern construction. It has been a common practice during the history of a cavern to store the data in file cabinets, in hand-made overviews and sketches, on spreadsheets or even as scattered notes. In addition to that, quite a large amount of specific knowledge was only stored in the mind of engineers. Much of this will be made available to the company by utilizing CavBase.

The developed database-system CavBase is a specifically designed tool which organizes (stores, collects, retrieves) all data relevant to any type of cavern operation. The initial reason for developing this type of database was to minimize the enormous amount of time which is always required to retrieve data from the different kinds of media when needed to make preparations for any kind of decision. Additionally the data handling is minimized, including errors due to retyping. CavBase therefore conforms to ISO 9000 quality requirements, where the company has to check the data conformity and validity during the whole process of cavern construction. Applying the “controlled conditions” for the “approval of processes” which are required by ISO 9001 is fulfilled by CavBase once the program itself had been subject to quality control.

## 2 General concept

All data characterizing the cavern construction process are at least linked to one of two general criteria: TIME and DEPTH (fig. 1). Data records in tables and worksheets related to TIME are, e.g. chemical analysis, pressure, quantities or calculated production rates. Bore hole or cavern shape information, distances and volumes are always linked to a DEPTH value.

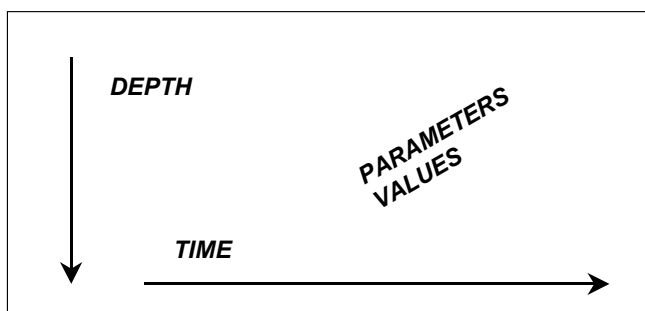

Figure 1: Depth & Time Relation

At the beginning of the history of cavern construction technology these data were recorded primarily in books and tables. With the growth in computer technology, the data from tables and books as well as from automatically stored records have been transformed into graphs, either with TIME-axis on the horizontal or DEPTH-axis on the vertical position. The increasing possibilities to visualize any type of data regarding the cavern technology has initiated major improvements during the last 15 years due to the greater use of computers.

Even with increasingly better computer hard- and software technology, many man-hours are still spent today in preparing outputs summarizing and visualizing cavern information. While solutions for single aspects of cavern technology already exist, (e.g. visualization of cavern shape in two or three dimensions, completion and bore hole details, logging results, mapping of caverns) the programming of CavBase follows the intention to create a tool which assists in all aspects of cavern construction, mining process and storage business.

Because each cavern field location has its own characteristics and no location is comparable to another, the major challenge is to produce a software package which can be applied in as many locations as possible.

### 3 Data Base Environment

The organization of the system is shown in fig. 2. Two executable or program files are needed for the database system. The server-program organizes the access to the database and is located on a server or central PC. The client-program is always installed on a local PC and contains all program features such as input, output and visualization. The strict isolation of the server and client parts provides for maximum flexibility in many points. The data itself presents the value for the company. Storing it on the server has many advantages over the option of keeping it with the client PC: It will be subject to the corporate backup procedures and safety and access restrictions. Besides that the client PC need not necessarily be in the same LAN (local area network), but can be tied to the server through the Internet or by the corporate WAN (wide area network). On the other hand, both server and client components can reside on the same work station, forming a single CPU, a single user system. This will be the choice wherever a client-server-network would be overkill.

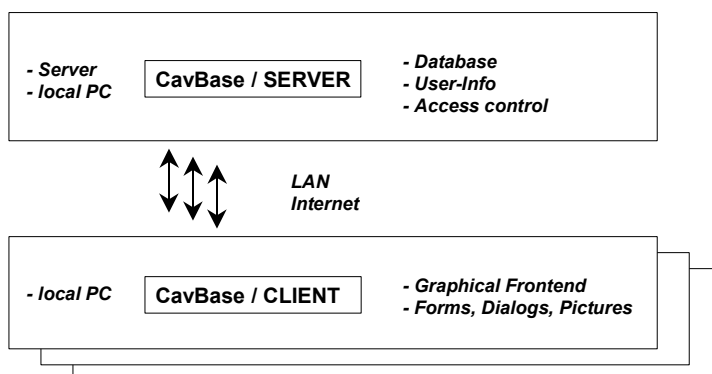

Figure 2: Environment of CavBase system

This type of organization allows the whole software package to be applied in most companies to their existing network solutions.

## 4 Internal Database Structure

Typically the following information has to be collected in order to operate solution-mined caverns:

- bore hole data (e.g. coordinates, deviations, logging results, chemical and physical properties of the salt),
- technical data (e.g. completion design, casing depths, material specifications, hydraulic calculations, as-built drawings, P&IDs),
- echometric cavern measurements (and blanket level measurements) and
- production details (e.g. water and brine quantities, individual well-head pressures, analytical results, blanket inventories).

All information is organized according to the following hierarchical structure (fig. 3).

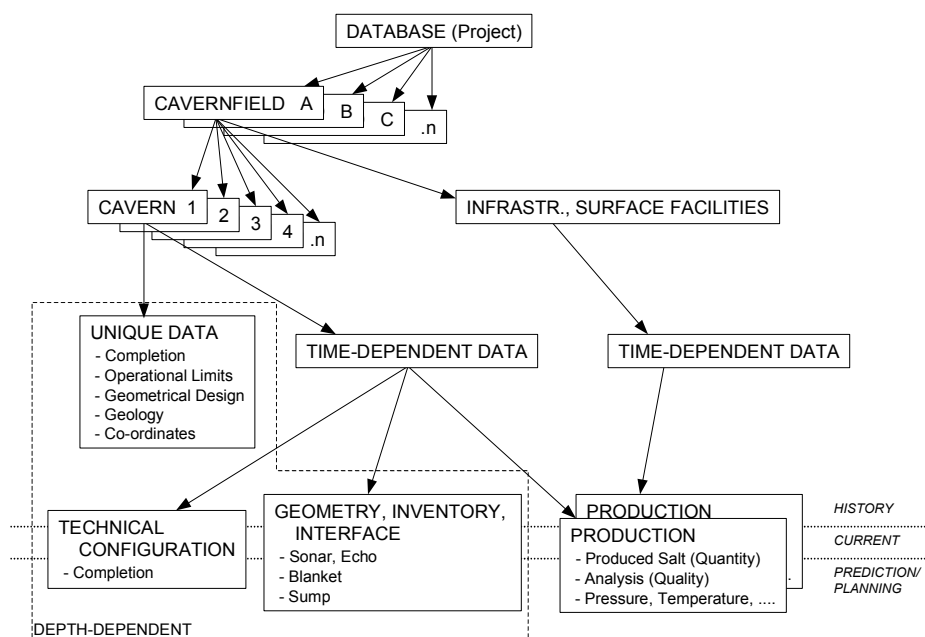

Figure 3: Structural concept of CavBase system

One database project is organized in one single database file. Inside this project it is possible to manage different cavern fields. If more than one project needs to be handled by a single person or a group of engineers / geologists / operators, different database files are created, organized and selected while switching on the computer

Inside a cavern field an unlimited number of caverns and bore holes can be organized and administered. Besides the caverns, several surface technical units can be defined. Such units are typically the water and the brine flow system. But any other system, like e.g. multiple fresh water or undersaturated brine supply can be represented in case there are more complicated cavern field systems.

As mentioned above, the cavern data can be subdivided into TIME- and DEPTH-related information. Some of the data; and these are the most important ones; have both TIME and DEPTH attributes simultaneously.

## 5 Data Input, Input Data

To maintain a successful database system, a necessary but in many cases boring and time-consuming data input process has to be performed. It is one of the major goals of the CavBase development to make the data handling and input as easy as possible. Table 1 shows a few of the different data types, some examples and how the data management has to be performed.

DATA - TYPE	INPUT – EXAMPLES	DATA – MANAGEMENT	FREQUENCY
PROJECT, CAVERNFIELD	LOCATION, UNITS, LANGUAGE	MANUAL	ONCE
CAVERNSHAPE	SONAR SURVEYS	DIFFER. ASCII-FORMATS	AFTER SONAR
BLANKET LEVEL	WIRELINE LOGGING	MANUAL	AFTER SURVEY
COMPLETION	PIPESHOE-DEPTH	MANUAL	AFTER WORKOVER
PRODUCTION	QUANTITY, ANALYSIS	ASCII, DIRECTLY FROM SPS, MANUAL (OPERATOR)	DAILY OR WEEKLY

Table 1

In small cavern fields, or in case of operating a single cavern, it might be sufficient to update production data manually on a daily base. If operators are performing this procedure on site, they will benefit from the menu-driven input performance which helps to avoid errors during data input and which forces the operator to judge critically the day-by-day operation. In cavern-fields with more than 3 to 5 caverns it is more efficient to establish an automatic routine for data acquisition. This is performed either directly from the operation system or with the help of, e.g., intermediate daily updated temporary files. In the latter case data validation or critical check of data correctness is performed by adequate visualization of all data.

Sonar data from several suppliers are typically available as ASCII formatted data. They are introduced to the database system with files on disks or via Internet. The same procedure is used to incorporate cavity data from cavern simulation results.

Production data, cavern shape data and logging data, based on their bare occurrence, make up more than 95% of the total amount. The remaining data regarding cavern configuration changes or controls (e.g. blanket, pipe-setting) rarely appear and are added manually.

The philosophy for these data is a unique manual input which; in many cases, is remote from currently existing habits of multiple manual input into many different applications, tables and sheets.

## 6 Data Extraction and Visualization

The most important and attractive unit of the whole system is the data extraction and visualization part. Typical output features are:

- Reports (daily, weekly, monthly, yearly);
- Lists, Tables;
- Cavern Overviews (with logs, shapes, geology, completions);
- Graphs (X-Y-Diagrams).

All the graphs and reports can be tailored by the individual user and stored in his personal or his group's environment for easy access.

As described above, the two major criteria are TIME and DEPTH. As an example of the several output features, the following X-Y-Graph (fig. 4) combines TIME and DEPTH in one diagram.

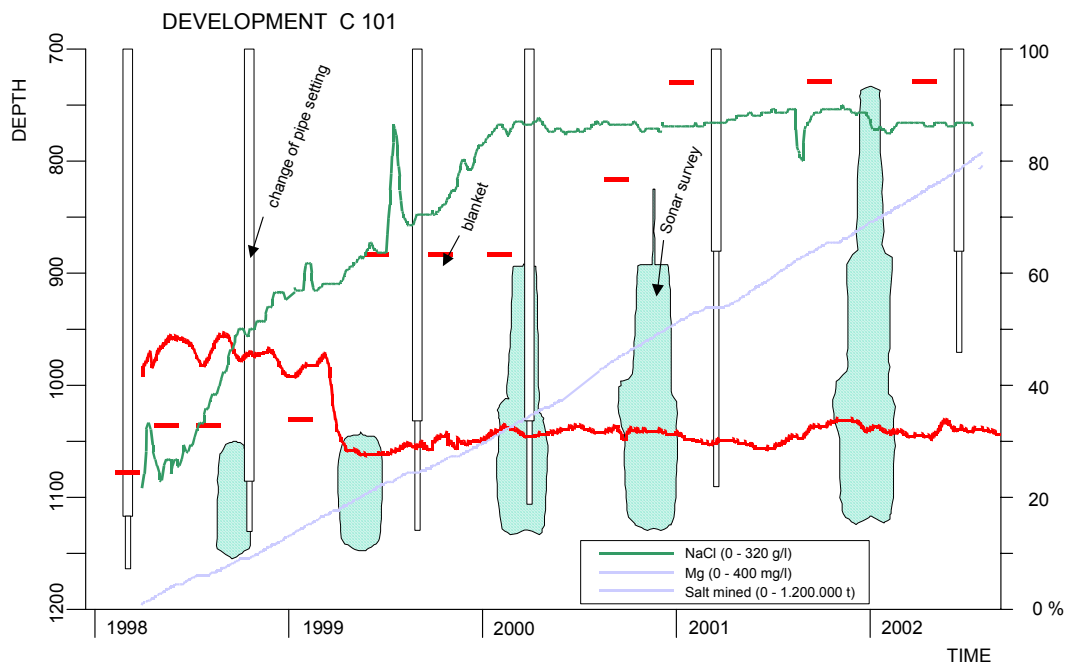

Figure 4: TIME-DEPTH-Diagram with selectable and editable sketches, parameters and axis

The user has the possibility of creating these graphs in accordance with his own requirements. The time-graphs with a horizontal time scale (x-axis) can be combined with a vertical axis showing either depths or any other parameter. The y-axis serves as the major axis and can be combined with one right y-axis having a Minimum (0) and Maximum (100%). Min and Max are defined separately and illustrated on the attached legend. Furthermore, once the definition of a graph has been completed the users are able to store the graph-settings and retrieve them during the next session. Those definitions are stored on the server as user-specific and are therefore independent of the settings on the PC.

While programming the CavBase system the major effort was spent on flexibility for the users, on their being able to define the outputs according to their own specific needs. The performance and the success of this system strictly depends on this freedom of the user to create his own outputs, tables, pictures and graphs.

## **7 Benefits and Perspectives of the CavBase Development Presented**

The benefits of the system presented, compared to historically developed local approaches are:

- Avoidance of multiple data input;
- Automated and controllable data input;
- Data storage in a unique environment and in a defined structure;
- Easy data retrieval and data visualization (charts, diagrams, etc.);
- Improved “trial and error” approach to cavern construction;
- Database validity and integrity;
- Access to the same database for all different users.

The major results of the advantages described above are:

- Optimization of the decision process and reduction of the time required for discussion;
- Keeping and storing easily accessible data;
- Keeping cavern leaching and construction experiences and discussing them;
- Quality control;
- Time-saving;
- Cost-saving.

CavBase data handling and subsequent processing and visualization is programmed 100% in C++ and utilizes an SQL database system in the background for the data storage and retrieval. The CavBase system can be used as a single solution without any additional need of other related software packages. Alternatively, links are available to use the programs of the CavSuite system, to analyze cavern shapes (CavView) and logs (CavLog) and to visualize caverns in three-dimensional environment (CavMaps, CavWalk). The basic version of the CavBase will be available within the next months. The software testing started recently and is being conducted in four cavern field locations of different customers.